

Banked Fryer

Model EOF-20/24/24



Now you're Cooking!

You can increase productivity and take profits to the "Bank" with the Giles Banked Fryer.

The Giles Banked Fryer is designed for foodservice operations needing large quantities of product cooked quickly. In the space saver configuration, the Giles Banked Fryer can produce tremendous amounts of fried products quickly. And with our fast recovery times, you won't waste time waiting for oil that has lost its temperature.

The Giles Banked Fryer is simple to use. The durable, accurate timing system is engineered to be user friendly. All controls for the built-in filtering system are located in a central section of the fryer to minimize workload and make filtering easy. A two basket Giles Autolift System comes standard on the 20" vat. Other options include a melt cycle for Canadian units and customization of the type of cooking compartments with one 20 inch and up to two 24 inch units combined into a single Giles Banked Fryer.

Design Features

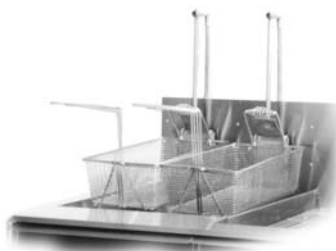

Automatic Basket Lift

The Automatic Basket Lift enables the operator to load the fryer, set the timer and activate the basket lift in one step. When the frying cycle is complete, the basket is automatically raised out of the shortening, allowing for safe and easy unloading of the product.



Automatic Oil Filtration System

Designed to complete a filter cycle within five minutes, the Automatic Oil Filtration System, which uses disposable filter paper, allows the operator to drain, clean and filter the oil in one motion. Refilling the Fry Vat is automatic. The system can increase your shortening life by 50%.

Listings



Giles Foodservice Equipment

An ISO 9001 Registered Company

2750 Gunter Park Drive West • Montgomery, AL 36109 USA

Phone 334.272.1457 • Fax 334.272.3561 • Phone Toll Free 1.800.554.4537

Web Site: www.gilesent.com • Email: info@gilesent.com

Banked Fryer

Model EOF-20/24/24

Item No.: _____
 Quantity: _____
 Project Name: _____
 SIS#: _____
 AIA/CSI#: _____

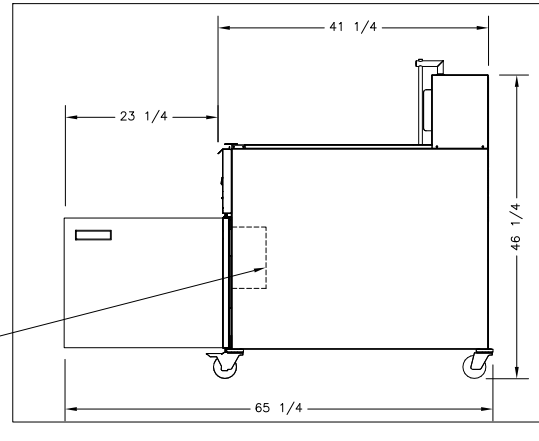
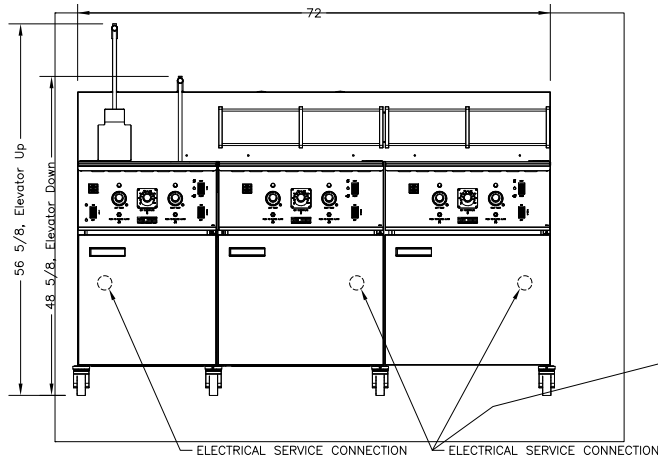

Inches [millimeters]

Front

Side

Specifications

We reserve the right to change specifications and product design without notice. Such revisions do not entitle the buyer to corresponding changes, improvements, additions or replacements on previously purchased equipment.

Construction:

Cabinet and Fry Vat: 20Ga to 16Ga Stainless Steel
 Heating Element: Stainless Steel Round

Cooking Computer (1) per vat:

- (1) Adjustable Cooking Temperature, Max. Temperature: 375°F [190°C]
- (2) Timer Cycles, each cycle with (4) presets
- High Limit Thermostat: 450°F [220°C]

Capacity:

- 20" Vat: Shortening Capacity: 115 lbs. [52 kg]
 Production Capacity: 27-30 lbs [12-14 kg] of cut chicken (80 pieces) using 3-1/2 lb [1.5 kg] bird.
- 24" Vat: Shortening Capacity: 170 lbs. [77 kg]
 Production Capacity: 36-42 lbs [16-19 kg] of cut chicken (96 pieces) using 3-1/2 lb [1.5 kg] bird.

Electrical Specifications:

- Available voltages: 208/240/480V -20" Vat -24,000 WATTS
 -24" Vat -30,000 WATTS
- 20" Vat -3 phase - 208/240/480V - 76/66/33 AMPS
- 24" Vat -3 phase - 208/240/480V - 100/87/43 AMPS
- (No service cord provided)

Listings:

UL (US and Canada), UL Sanitation, CE

Shipping Specifications:

- Crated Weight: 1069 lbs [485 kg] EOF-20/FFLT/24
- Crated Weight: 1311 lbs [595 kg] EOF-20/FFLT/24/24
- Crated Cube Size: 50" D X 108" L X 61" H = 190.6 cu ft
 [1270mm X 2743mm X 1549mm = 5.4 cu meters]

Accessories Included

Unit is shipped with (4) Fry baskets - (Product Scoop may be substituted for (2) Baskets), (2) Fry Screens, (1) Drain hose wand, (5) Filter paper sheets, (1) Pot brush, (1) Kettle drain brush, (1) Stir paddle, (1) Crumb shovel, (1) Vat drain clean out bar and (1) Manual.

How To Specify

1. Model and Electrical Options

Specify the part number from the following:

	Voltage	Hz	Phase	Model	Part Number
<input type="checkbox"/>	208	60	3	EOF-20/24/24	70981
<input type="checkbox"/>	240	60	3	EOF-20/24/24	70982
<input type="checkbox"/>	480	60	3	EOF-20/24/24	70983

2. Accessories*

Specify the part number and quantity of the following accessory items needed:

	Qty	Description	Part Number
<input type="checkbox"/>		Product Scoop	70430
<input type="checkbox"/>		Basket, EOF-20	70420
<input type="checkbox"/>		Basket, EOF-24	70421
<input type="checkbox"/>		Filter Paper, (100) Sheets	60328
<input type="checkbox"/>		Filter Powder, (60) packets	72004
<input type="checkbox"/>		Boil Out (4) 8 lb containers	72003

*Additional charges

3. Shipping

Specify the shipping method

Giles Foodservice Equipment

2750 Gunter Park Drive West • Montgomery, AL 36109 USA

Phone 334.272.1457 • Fax 334.272.3561 • Phone Toll Free 1.800.554.4537

Web Site: www.gilesent.com • Email: info@gilesent.com